

200W motor (Note 3.)

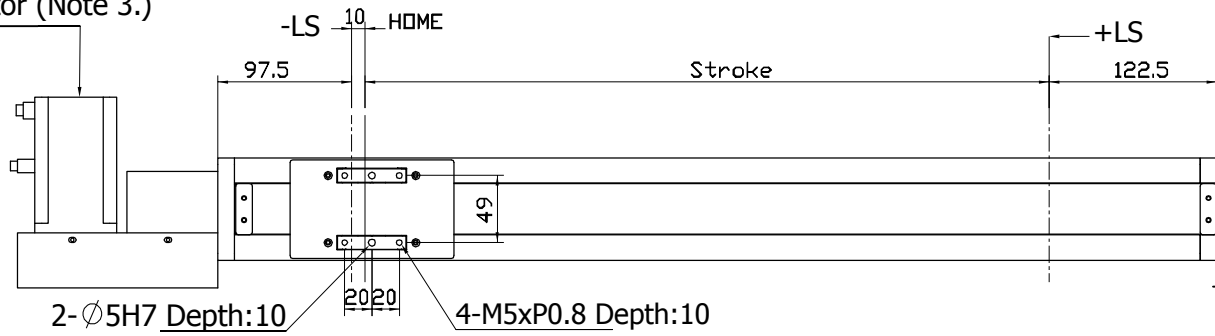

<JDTNS-75> Specification

- Note:1.The dimension of motor can e BL or BR
 2.We install the sensor outside.(right or left side) (optional accessory)
 3.Applicable motor:100,200W,400W.

Ø 4 Hole of negative pressure exhaust

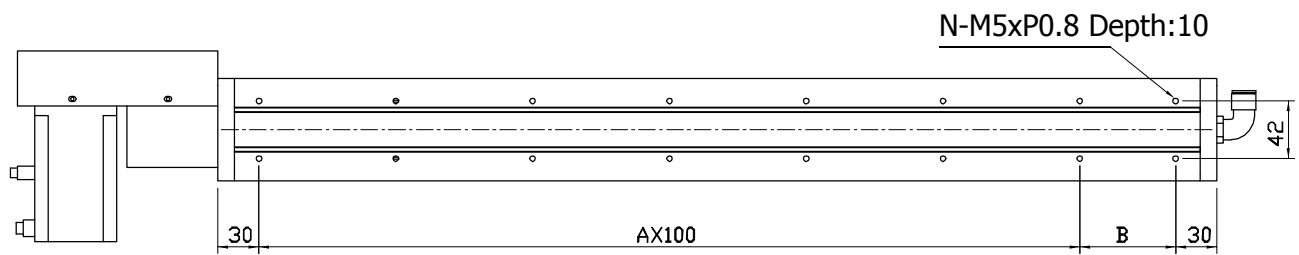
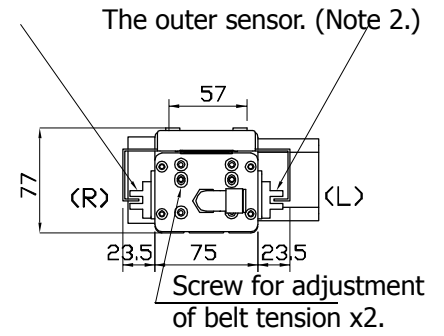
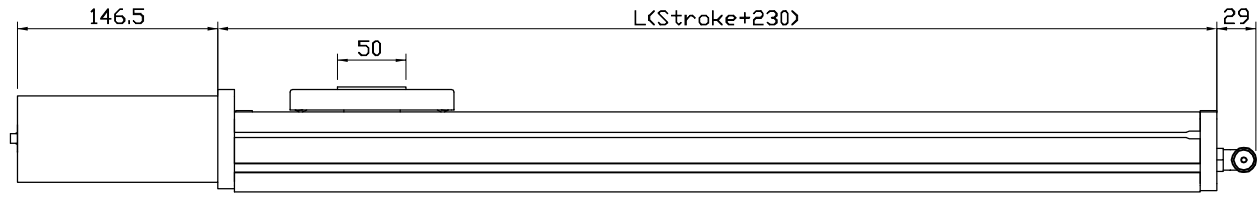

SENSOR Operation:
 1.+LS
 2.HOME
 3.-LS

Unit:mm

Stroke	100	200	300	400	500	600	700	800	900	1000	1100	1200
L	330	430	530	630	730	830	930	1030	1130	1230	1330	1430
A	2	3	4	5	6	7	8	9	10	11	12	13
B	70	70	70	70	70	70	70	70	70	70	70	70
N	8	10	12	14	16	18	20	22	24	26	28	30
Weight(kg)	4.0	5.0	6.0	7.0	8.0	9.0	10.0	11.0	12.0	13.0	14.0	15.0